

0149.P130 - CAM ROLLER P130

FORZA INIZIALE DI ESTRAZIONE / INITIAL EXTRACTION FORCE **170 daN**
 RÜCKZUGSKRAFT / FORCE INITIALE D'EXTRACTION
 FORZA FINALE DI ESTRAZIONE / FINAL FORCE OF EXTRACTION **250 daN**
 ENDKRAFT DER EXTRACTION / FORCE FINALE D'EXTRACTION

SFORZO MAX TRANCIO **4500 daN**
 CUTTING MAX FORCE
 MAXIMALE SCHNITTKRAFT
 EFFORT MAXI DÉCOUPE

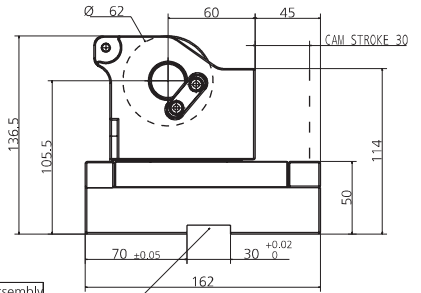
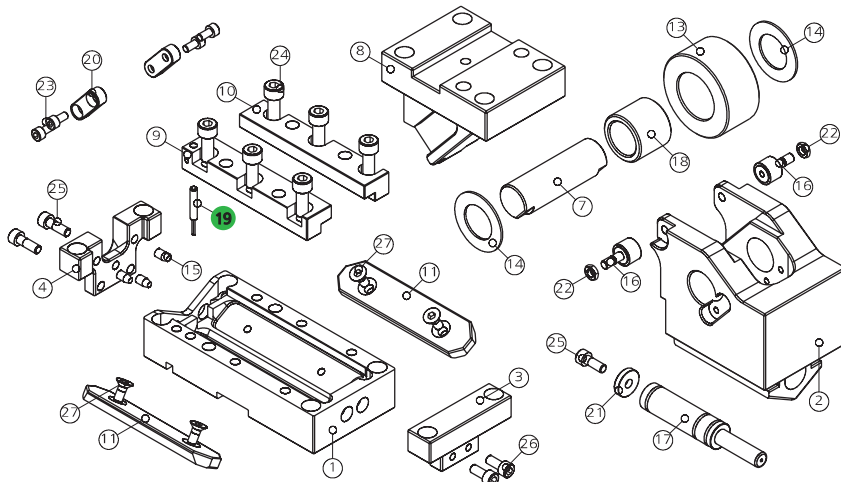

We suggest you to assembly by using a thrust mount key

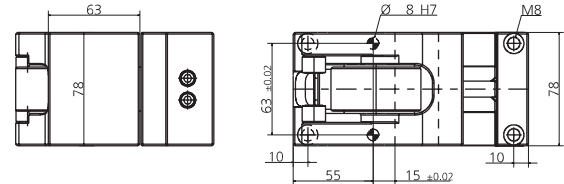

POS.	CODE	DESCRIPTION	Q.TY
001	8000.0049.0130	CORPO CAMMA / CAM BODY / GRUNDGEHÄUSE	1
002	8007.0049.0100	SLITTA / SLIDER / LAGERKEIL	1
003	8088.0049.0100.001	PIASTRINA / PLATE / PLATTE	1
004	8088.0049.0100.002	PIASTRINA / PLATE / PLATTE	1
007	8005.0780.0617.250.001	PERNO / PIN / STIFT	1
008	8090.0001.0030.000	CUNEO / WEDGE / DRUCKSTÜCK 0	1*OPTION
008	8090.0001.0030.605	CUNEO / WEDGE / DRUCKSTÜCK +5	1*OPTION
008	8090.0001.0030.610	CUNEO / WEDGE / DRUCKSTÜCK +10	1*OPTION
008	8090.0001.0030.615	CUNEO / WEDGE / DRUCKSTÜCK +15	1*OPTION
008	8090.0001.0030.705	CUNEO / WEDGE / DRUCKSTÜCK -5	1*OPTION
008	8090.0001.0030.710	CUNEO / WEDGE / DRUCKSTÜCK -10	1*OPTION
008	8090.0001.0030.715	CUNEO / WEDGE / DRUCKSTÜCK -15	1*OPTION
008	8090.0001.0030.720	CUNEO / WEDGE / DRUCKSTÜCK -20	1*OPTION
008	8090.0001.0030.725	CUNEO / WEDGE / DRUCKSTÜCK -25	1*OPTION
008	8090.0001.0030.730	CUNEO / WEDGE / DRUCKSTÜCK -30	1*OPTION
008	8090.0001.0030.735	CUNEO / WEDGE / DRUCKSTÜCK -35	1*OPTION
008	8090.0001.0030.740	CUNEO / WEDGE / DRUCKSTÜCK -40	1*OPTION
008	8090.0001.0030.745	CUNEO / WEDGE / DRUCKSTÜCK -45	1*OPTION
008	8090.0001.0030.750	CUNEO / WEDGE / DRUCKSTÜCK -50	1*OPTION
009	8086.1190.0235.180.001	GUIDA ANGOLARE / SIDE PLATE L / WINKELFÜHRUNG FÜHRUNGSSCHIENE	1
010	8086.1190.0235.180.002	GUIDA ANGOLARE / SIDE PLATE L / WINKELFÜHRUNG FÜHRUNGSSCHIENE	1
011	8012.1200.0270.080.001	PIASTRA DI SCORRIMENTO / WEAR PLATE / DRUCKPLATTE	2
013	8004.0620.0305.350.001	ROTELLA / ROLLER / ROLLE	1
014	9033.2644.015	RALLA / THRUST WASHER / DRUCKSCHEIBE	2
015	9020.06.10.E090	PUNTALINO / BUMP STOP / DRUCKSTÜCK	3
016	8005.0270.0110.160.001	PERNO / PIN / STIFT	2
017	9000.0038.0019.007	CILINDRO AD AZOTO / NITROGEN CYLINDER / STICKSTOFFZYLINDER	1
018	9035.2535.300.001	BOCCOLA / BUSH / BUCHSE	1
019	9003.0002	SENSORE DI SICUREZZA / SECURITY SENSOR / SENSOR FÜR SICHERHEIT	1*OPTION
020	8087.0350.0120.080.001	CHIAVETTA / KEY / SCHLÜSSEL	2
021	8089.0198.0040.001	DISTANZIALE / SPACER / ABSTANDSHALTER	1
022	9014.06.005.008.1.4032	DADO / NUT / MUTTER M6	2
023	9007.05.010.129.1.4762	VITE / SCREW / SCHRAUBE M5X10	4
024	9007.08.020.129.1.4762	VITE / SCREW / SCHRAUBE M8X20	6
025	9007.06.020.129.1.4762	VITE / SCREW / SCHRAUBE M6X20	3
026	9007.06.014.129.1.4762	VITE / SCREW / SCHRAUBE M6X14	2
027	9007.06.014.129.1.5933	VITE / SCREW / SCHRAUBE M6X14	4

POSSIBILI INCLINAZIONI / POSSIBLE INCLINATIONS / MÖGLICHE NEIGUNGEN

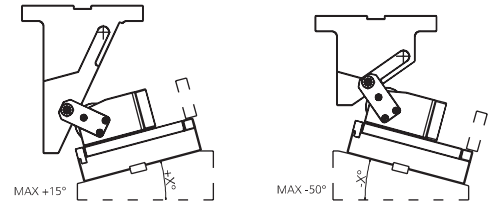

008 (8090) CUNEO / WEDGE / DRUCKSTÜCK

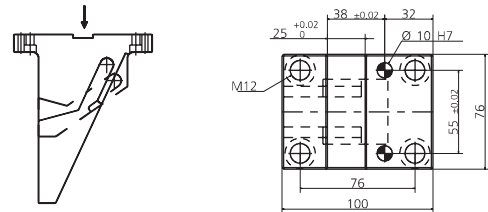

019 (9003) SENSORE / SENSOR / SENSOR



19 PATENT PENDING

MODELLO D'ORDINE / ORDER EXAMPLE / BESTELLBEISPIEL / MODÈLE DE COMMANDE

MODEL **0149.P130** INCLINATION **+10°** OPTION CODE **9003.0002**