

POS.	DESCRIPTION	Q.TY
001	CORPO CAMMA / CAM BODY / GRUNDGEHÄUSE	1
002	SLITTA / SLIDER / LAGERKEIL	1
003	CUNEO / WEDGE / DRUCKKEIL	1
004	STAFFA DI AGGANCIO / BRACKET ATTACHMENTS / BRACKETBEFESTIGUNG	1
005	STAFFA DI AGGANCIO / BRACKET ATTACHMENTS / BRACKETBEFESTIGUNG	1
006	PIASTRA DI SCORRIMENTO / WEAR PLATE / DRUCKPLATTE	4
007	PIASTRA DI SCORRIMENTO / WEAR PLATE / DRUCKPLATTE	2
008	PIASTRA DI SCORRIMENTO / WEAR PLATE / DRUCKPLATTE	2
009	PIASTRA DI SCORRIMENTO / WEAR PLATE / DRUCKPLATTE	1
010	PIASTRA DI SCORRIMENTO / WEAR PLATE / DRUCKPLATTE	1
011	PIASTRA DI SCORRIMENTO / WEAR PLATE / DRUCKPLATTE	2
012	SUPPORTO CILINDRO / CYLINDER HOLDER / ZYLINDERHALTERUNG	2
013	PIASTRINA / PLATE / PLATTE	1

POS.	DESCRIPTION	Q.TY
014	CHIAVETTA / KEY / SCHLÜSSEL	1*OPTION
015	CHIAVETTA / KEY / SCHLÜSSEL	1*OPTION
016	DISTANZIALE / SPACER / ABSTANDSHALTER	4
017	VITE / SCREW / SCHRAUBE M16X45	15
018	VITE / SCREW / SCHRAUBE M10X30	4
019	VITE / SCREW / SCHRAUBE M10X20	12
020	VITE / SCREW / SCHRAUBE M10X25	8
021	VITE / SCREW / SCHRAUBE M10X25	14
022	VITE / SCREW / SCHRAUBE M8X20	1
023	VITE / SCREW / SCHRAUBE M6X20	8
024	VITE / SCREW / SCHRAUBE M6X14	8
025	CILINDRO AD AZOTO / NITROGEN CYLINDER / STICKSTOFFZYLINDER	3
026	PUNTALINO / BUMP STOP / STOSSDÄMPFERSPITZE	3

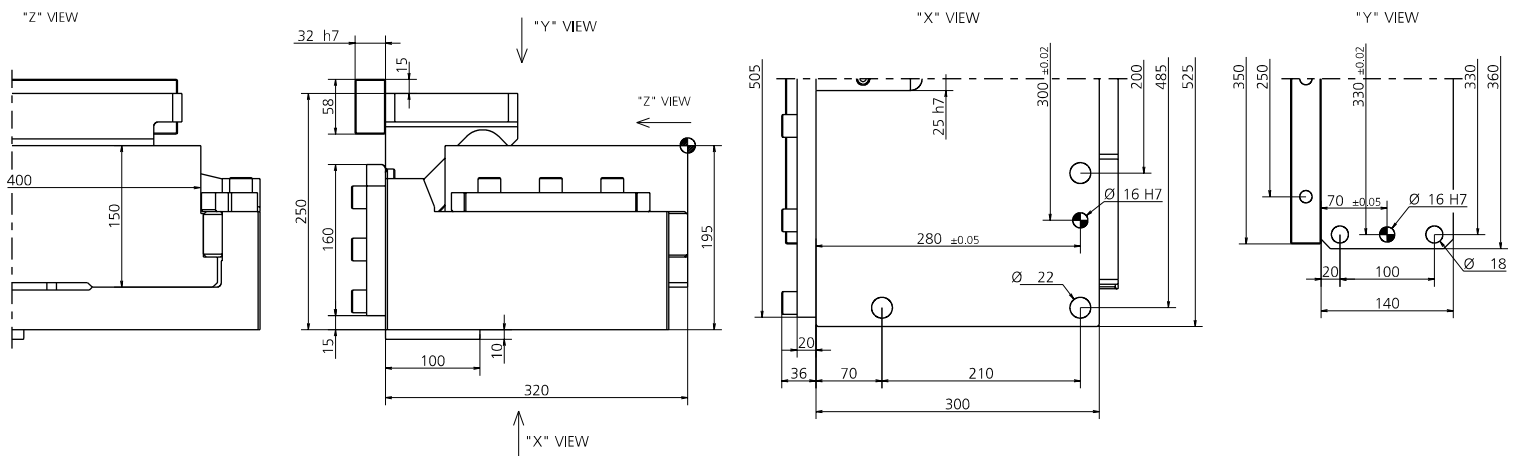

CODE	CAM STROKE	PRESS STROKE	EXTRACTION FORCE (daN)	CUTTING FORCE (daN)
0152.4060-00	60	60	2520	48000