

POS.	DESCRIPTION	Q.TY
001	CUNEO / WEDGE / DRUCKKEIL	1
002	SLITTA / SLIDER / LAGERKEIL	1
003	CORPO CAMMA / CAM BODY / GRUNDGEHÄUSE	1
004	STAFFA DI AGGANCIO / BRACKET ATTACHMENTS / BRACKETBEFESTIGUNG	2
005	PIASTRINA / PLATE / PLATTE	2
006	DISTANZIALE / SPACER / ABSTANDSHALTER	2
007	STAFFA / BRACKET / BRACKET	1
008	STAFFA / BRACKET / BRACKET	1
009	FINECORSO / LIMIT SWITCHES / ENDSCHALTER	2
010	PIASTRA DI SCORRIMENTO / WEAR PLATE / DRUCKPLATTE	2
011	CILINDRO AD AZOTO / NITROGEN CYLINDER / STICKSTOFFZYLINDER	2
012	PUNTALINO / BUMP STOP / STOSSDÄMPFERSPITZE	4

POS.	DESCRIPTION	Q.TY
013	SENSORE DI SICUREZZA / SECURITY SENSOR / SENSOR FÜR SICHERHEIT	1*OPTION
014	PIASTRA DI SCORRIMENTO / WEAR PLATE / DRUCKPLATTE	2
015	PIASTRA DI SCORRIMENTO / WEAR PLATE / DRUCKPLATTE	1
016	CHIAVETTA / KEY / SCHLÜSSEL	2
017	PIASTRA DI SCORRIMENTO / WEAR PLATE / DRUCKPLATTE	4
018	CHIAVETTA / KEY / SCHLÜSSEL	4
019	PIASTRA DI SCORRIMENTO / WEAR PLATE / DRUCKPLATTE	2
020	FINECORSO / LIMIT SWITCHES / ENDSCHALTER	1
021	CUNEO / WEDGE / DRUCKKEIL	1
022	CUNEO / WEDGE / DRUCKKEIL	1
023	PIASTRA DI SCORRIMENTO / WEAR PLATE / DRUCKPLATTE	1

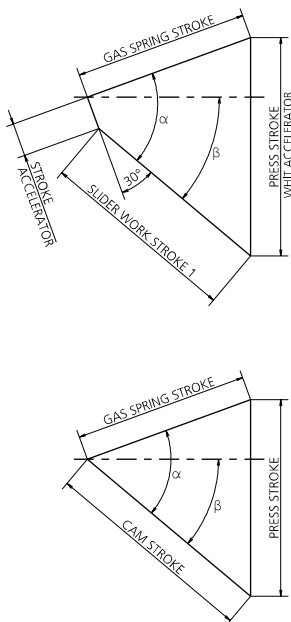

β	α	CAM STROKE	SLIDER WORK STROKE 2	PRESS STROKE	PRESS STROKE WITH ACCELERATOR	STROKE ACCELERATOR	GAS SPRING STROKE	EXTRACTION FORCE (daN)	CUTTING FORCE (daN)
0°	50°	37.28	28.62	44.43	49.43	10	58	8700	115500
5°	50°	41.17	32.94	44.6	49.62	10	58	8700	115500
10°	55°	41.64	33.87	48.24	53.32	10	58	8570	115500
15°	55°	46	38.68	49.19	54.36	10	58	8570	115500
20°	55°	50.56	43.71	50.56	55.89	10	58	8570	115500
25°	60°	52.42	46.09	55.42	60.94	10	58	8380	115500
30°	60°	58	52.22	58	63.78	10	58	8380	115500
35°	65°	61.32	56.16	64.17	70.27	10	58	8120	115500
40°	65°	68.62	64.15	68.62	75.15	10	58	8120	115500
45°	70°	74.34	70.68	77.08	84.15	10	58	7800	115500
50°	70°	84.79	82.09	84.79	92.57	10	58	7800	115500
55°	75°	95.02	/	97.67	/	/	58	7410	115500
60°	75°	112.05	/	112.05	/	/	58	7410	115500
65°	80°	102.85	/	104.86	/	/	45	6930	115500
70°	85°	127.09	/	131.07	/	/	45	6450	115500
75°	85°	114.15	/	115.47	/	/	30	6680	115500

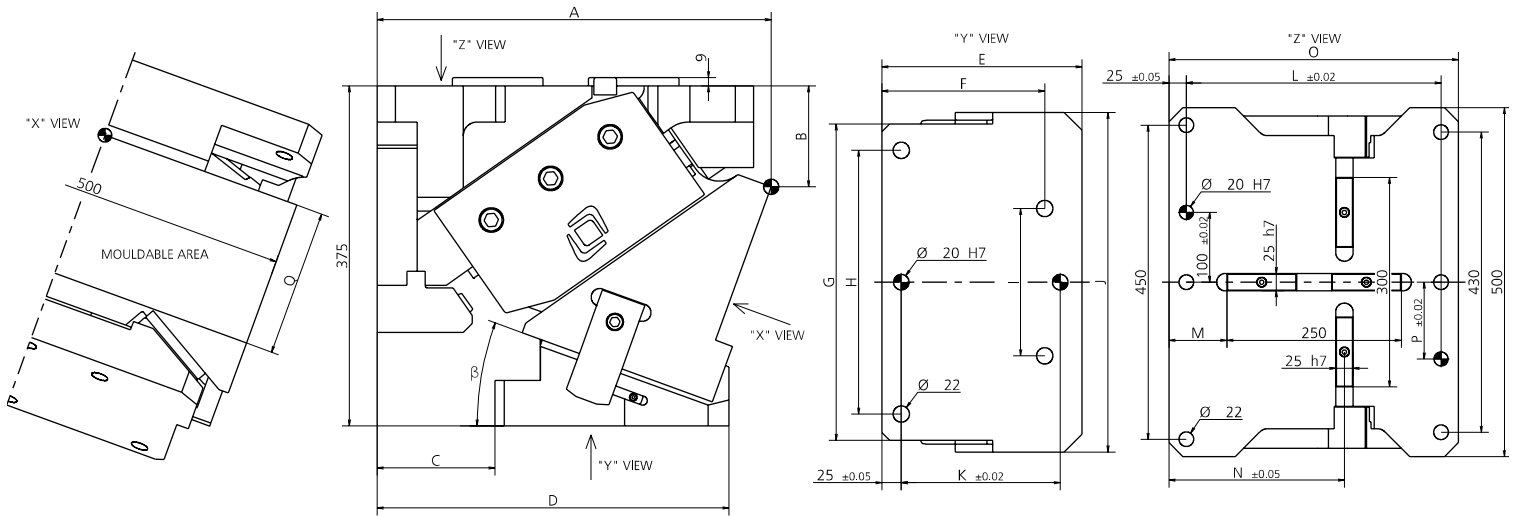

CODE	β	A	B	C	D	E	F	G	H	I	J	K	L	M	N	O	P	Q
0150.0500-00	0°	403	75	130	396	266	185	408	340	190	438	205	365	83	209.5	415	110	180
0150.0500-05	5°	410.89	94.3	130	398	268	185	408	340	190	438	205	365	83	220	415	110	180
0150.0500-10	10°	418.81	99.28	130	384	254	185	408	340	190	438	205	365	83	230.5	415	110	180
0150.0500-15	15°	426.7	104.96	130	385	255	185	408	340	190	438	205	365	83	241	415	110	180
0150.0500-20	20°	434.51	111.32	130	376	246	185	408	340	190	438	205	365	83	251.5	415	110	180
0150.0500-25	25°	417.16	118.36	80	339	259	145	408	340	190	438	175	365	83	237	415	110	180
0150.0500-30	30°	424.16	131.06	80	330	250	145	408	340	190	438	175	365	83	247.5	415	170	180
0150.0500-35	35°	427.78	150.13	80	317	237	145	408	340	190	438	175	365	83	256.5	415	110	180
0150.0500-40	40°	438.66	158.34	80	312	232	145	408	340	190	438	175	365	83	265.5	415	110	180
0150.0500-45	45°	395.15	172.88	30	255	225	145	408	340	190	438	175	401	103	224.5	455	110	180
0150.0500-50	50°	412.72	188.31	30	245	215	145	408	340	190	438	175	401	100.5	233.5	450	110	180
0150.0500-55	55°	423.22	212.08	30	256	226	145	408	340	190	438	175	401	100.5	241	450	110	180
0150.0500-60	60°	433.59	232.11	30	258	228	145	408	340	190	438	175	401	100.5	248.5	450	110	180
0150.0500-65	65°	434.62	242.64	0	245	245	140	500	463	463	500	175	401	100.5	248.5	450	110	180
0150.0500-70	70°	429.87	254.52	0	219	219	125	500	463	463	500	175	401	100.5	248.5	450	110	180
0150.0500-75	75°	418.49	262.53	0	208	208	105	500	463	463	500	160	401	100.5	233.5	450	110	180

13 PATENT PENDING

13 (9003) SENSORE / SENSOR / SENSOR



MODELLO D'ORDINE / ORDER EXAMPLE / BESTELLBEISPIEL / MODÈLE DE COMMANDE

MODEL **0150.0500** INCLINATION **-10°** OPTION CODE **9003.0001**